

#17-135 Power Trowel

Operator's Manual

Battery Walk-behind

Power Trowel

#17-135



Bon[®]
Trusted since 1958

4430 Gibsonia Rd. • Gibsonia, PA 15044 • USA • www.bontool.com

IS17135 9/24

Original instructions

This Operator's Manual presents the original instructions. The original language of the Operator's Manual is English.

This manual contains important instructions for this machine. These instructions must be followed during installation, operation, and maintenance of the machines.

This manual provides information and procedures to safely operate. For your own safety and to reduce the risk of injury, carefully read, understand, and observe all instructions described in this manual.

We reserves the right to change any of the contents in this manual without notice.

Warranty

Our products are covered by warranty for a period of twelve (12) months from the date of purchase against defects in material or workmanship provided that:

- The product concerned has been operated and maintained in accordance with the operating instructions.
- Has not been damaged by accident, misuse or abuse.
- Has not been tampered with or repaired by any unauthorized person.

Any evidence of failure to meet these conditions may result in a denial of the warranty claim.

The owner is responsible for the cost of transportation to and from the authorized repairer and the unit is at the owners risk while in transit to and from the repairer.

Impact damage is not covered under warranty.

Table of Contents

Foreword	3
Warranty	3
1. TECHNICAL DATA	5
1.1 Technical Specification.....	5
1.2 Dimension	5
2. SAFETY INFORMATION	6
2.1 Machine Description and Intended Use	6
2.2 Operating Safety.....	6
2.3 Safety regarding operation of machine.....	6-7
2.4 Electrical safety.....	7
2.5 Service Safety	7
2.6 Safety regarding maintenance.....	8
2.7 Label Locations.....	8
2.8 Labels Meaning	9
3. OPERATION	10
3.1 Preparing the Machine for First Use	10
3.2 Controls	10
3.3 Installing the Blades	11
3.4 Before Starting	11
3.5 Handle Installation and Adjusting	12
3.6 Safety Stop Switch	12
3.7 To Start	12
3.8 To Stop	12
3.9 Speed Control	13
3.10 Pitch Adjustment	13
3.11 Floating Operation.....	13
3.12 Finishing Operation.....	13
4. ELECTRICAL SCHEMATIC	14
5. MAINTENANCE	15
5.1 Periodic Maintenance Schedule.....	15
5.2 Battery Maintenance.....	15
5.3 Directions for Battery charger.....	15
5.4 Lubrication.....	16
5.5 Lifting Trowels.....	16
5.6 Trouble Shooting	17
6. MACHINE ACCESSORIES	17

1. Specification

The power trowel with battery is available in operated with rechargeable battery pack.

To find the specifications that apply to your machine, check the information plate on the machine.

1.1 Technical Specification:

Model		CT436E
Motor type		DC60V
Motor speed	r/min	4000
Power	kw	1.2
Operating weight (wo battery)	kg	94
Blade speed	rpm	0-140
Rotor Dia.	cm(in)	92(36)
Finishing Blade	in	6x14
Combination Blade	in	8x14
Float Pan	in	37

Battery: 60V/52AH (Optional)

Battery weight: 18kg

1.2 Dimension (L X W X H) : 1740mm*975mm*881mm

2. SAFETY INFORMATION

2.1 Machine Description and Intended Use

This machine is a walk-behind concrete finishing trowel. It consists of a motor mounted frame, a electrical motor, a battery pack, a gearbox, a guard ring and a handle.

This machine is intended to be used for floating and burnishing curing concrete.

2.2 Operating Safety

- Only trained personnel are permitted to start, operate, and shut down the machine. They have received instruction on how to properly use the machine and are familiar with required safety devices.
- Read, understand, and follow procedures in the Operator's Manual before attempting to operate the machine.
- The machine must not be accessed or operated by children and people impaired by alcohol or drugs.
- NEVER operate this machine in application for which it is not intended.
- NEVER allow anyone to operate this equipment without proper training. People operating this equipment must be familiar with the risks and hazards associated with it.
- Do not allow anyone to stank or lean on the unit during operation.
- ALWAYS Keep the safety stop switch system in adjustment and good operating condition at all times. Do not operate the trowel if it does not work properly. Out of control Trowels can cause serious personal injury and damage to fresh concrete surfaces. This system will automatically stop the unit if the operator loses control of it during operation.
- ALWAYS make sure the safety stop switch is disengaged (lever in the down position) before starting the unit. Keep one hand firmly on the handle while starting and do not let go of the handle during operation.
- ALWAYS wear protective clothing, safety glassed, hearing protection, safety-toed footwear to the job site while operating the machine.
- ALWAYS store the machine properly when it is not being used. The machine should be stored in a clean, dry location out of the reach of children.

2.3 Safety regarding operation of machine

- Recognized official procedures have to be used to ensure the machine is operated in safe and best conditions.
- Only operate the machine when all safety devices and related safety equipment are present and operational!
- Check the machine visually for any damage and defects at least once a day.
- In the event of operational malfunctions the machine must be shut down immediately and secured!
- Secure the work area around the machine in public areas providing a safety distance of at least 10 m (3.3 ft) from the machine.

- Faults must be immediately rectified.
- Carry out the switch on, and switch off operations in accordance with this user guide.
- Before switching on the machine make sure that no-one can be endangered when the machine starts up.
- Never operate the machine when it's in its upright position.
- All persons in the proximity of the machine must wear ear and eye protection as well as safety shoes. In addition the machine operator must wear close-fitting protective clothing.
- Make sure there is no debris in the work area.
- Check the work area for screws or other hard objects in the concrete. Don't use the machine if there are any foreign objects stuck into the surface. Such objects must be removed prior to operation of machine

2.4 Electrical safety

- Work on electrical equipment may only be undertaken by a skilled electrician or by trained persons under the supervision of a skilled electrician as well as in accordance with the local electrical engineering regulations.
- The electrical equipment for the plant must be inspected regularly. Defects must be rectified immediately. Call a skilled electrician or out customer services.
- A second person must be in attendance whilst the electrical engineer is working on the equipment.
- The work area must be secured against any third party entering the work area. Follow local electrical engineering regulations while working on the machine. Never leave a machine unattended. Use only tools that are insulated against electricity.
- Only start work after you are familiar with the electrical engineering regulations that apply to the local area.

2.5 Service Safety

- Read and understand the instructions contained in the manual delivered with the machine before servicing or maintaining
- Familiarize yourself with the location and proper use of all controls and safety devices before servicing or maintaining.
- Contact local dealer for additional training if necessary.
- Do not allow improperly trained people to service or maintain the machine. Personnel servicing or maintaining the machine must be familiar with the associated potential risks and hazards.
- Do not attempt to clean or service the machine while it is running. Rotating parts can cause severe injury.
- Do not remove blades while the machine is hanging overhead.
- When replacement parts are required for this machine, use only our replacement parts or those parts equivalent to the original in all types of specifications, such as physical dimensions, type, strength, and material.

2.6 Safety regarding maintenance

Set the machine into the OFF position before beginning any work on the machine.





- Never work on the machine while power is still connected!
- All parts must have come to a complete stop before beginning any work!
- Adjustment, servicing and inspection work on the period of time limits, specified in this User Guide as well as any information on the replacement or parts and equipment must be undertaken and/or complied with!
- These activities may only be undertaken by qualified personnel.
- The machine must not be connected to any power source while cleaning.

2.7 Label Location



2.8 Label Meanings

Our machines use international pictorial labels where needed. These labels are described below:

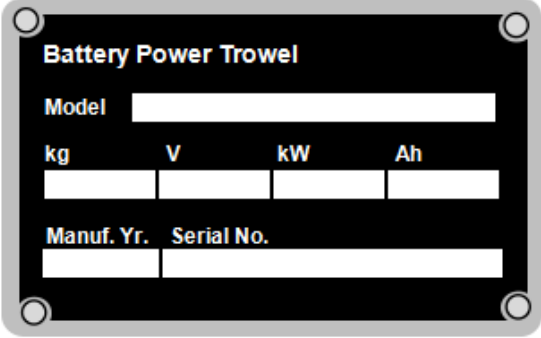
Label	Meaning
 <p>The label features a central orange rectangle with the word 'WARNING' in white, repeated in four languages: 'WARNING', 'WARNUNG', 'ADVERTENCIA', and 'AVERTISSEMENT'. On either side of the text are pictograms of a hand being cut by a blade, with a large 'X' over the scene. The label is marked 'PC110' at the bottom right.</p>	<p>WARNING! Cutting hazard. Always replace blade guard!</p>
 <p>The label has a yellow background with a black border. It features a pictogram of an open book on the left. On the right, the word 'CAUTION' is written in black, repeated in four languages: 'CAUTION', 'VORSICHT', 'PRECAUCION', and 'PRECAUCION'. The label is marked 'PC211' at the bottom right.</p>	<p>CAUTION! Read and understand the supplied Operator's Manual before operating the machine. Failure to do so increase the risk of injury to yourself or others.</p>
 <p>The label has a white background with a black border. It features a blue circular pictogram of a person wearing safety glasses and earplugs. Above the pictogram is the word 'WARNING' in orange, and below it are the words 'WARNING', 'ADVERTENCIA', and 'AVERTISSEMENT' in orange. The label is marked 'PC110' at the bottom right.</p>	<p>WARNING! Always wear hearing and eye protection when operating this machine.</p>
 <p>The label has a yellow background with a black border. It features a red upward-pointing arrow inside a circle, which is above a black hook pictogram. Below the pictogram, the word 'CAUTION' is written in black, repeated in four languages: 'CAUTION', 'VORSICHT', 'PRECAUCION', and 'PRECAUCION'. The label is marked 'PC200' at the bottom right.</p>	<p>CAUTION! Lifting point.</p>
 <p>The nameplate is black with white text and fields. It is titled 'Battery Power Trowel'. It contains the following fields: 'Model' with a blank line; 'kg', 'V', 'kW', and 'Ah' with blank lines; and 'Manuf. Yr.' and 'Serial No.' with blank lines.</p>	<p>A nameplate listing the model number and serial number is attached to each unit. Please record the information found on this plate so it will be available if the nameplate lost or damaged. When requesting service information, the serial number should be specified of the unit.</p>

3. OPERATION

3.1 Preparing the Machine for First Use

- 3.1.1 Make sure all loose packaging materials have been removed from the machine.
- 3.1.2 Check the machine and its components for damage. If there is visible damage, do not operate the machine! Contact dealer immediately for assistance.
- 3.1.3 Take inventory of all items included with the machine and verify that all loose components and fasteners are accounted for.
- 3.1.4 Add fluids as needed and applicable, including gearbox oil, lubricant and battery acid.
- 3.1.5 Make sure there is no debris in the work area.
- 3.1.6 Check the work area for screws or other hard objects in the concrete. Don't use the machine if there are any foreign objects stuck out from the surface. Before operate the machine such objects must be removed.

3.2 Controls

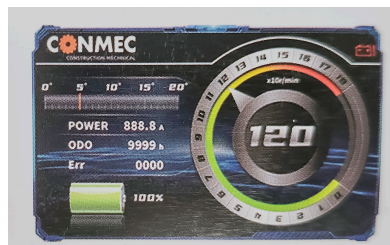
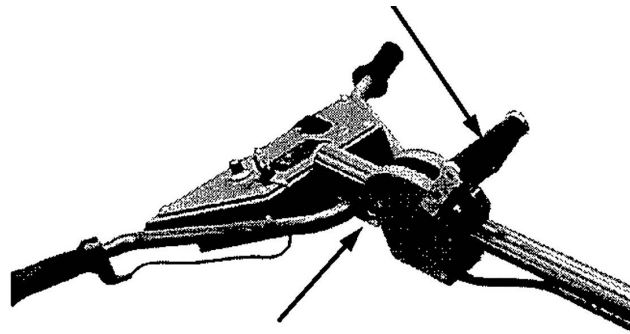

Ref. No.	Description	Ref. No.	Description
1	Power Indicator	2	Power (Key Switch)
3	Speed control on Auto	4	Manual/Auto for Speed Control
5	Safety stop switch	6	Blade Pitch Control
7	Display Screen	8	Speed Control on Manual

3.3 Installing the Blades

There are three types of blades available for the trowels. Float pans are large style blades, which hook on over finish or combination blades, used in the earliest stages of work, and are not pitched.

Finishing blades are used in the final stages of working, and are progressively pitched to burnish the concrete.

Combination blades can be used throughout the concrete working process. They are used in place of float pans and finishing blades.

Note: Do not put larger diameter blades on a smaller diameter trowel.

3.3.1 Finishing blades are flat on both edges and can be installed in either direction.

3.3.2 When installing combination blades, orient blades as bellow. This positions the raised edges of the blade correctly for the clockwise rotation of the machine.

3.3.3 Secure blades to trowel arms with screws (a). Dip threads of screws in grease prior to installation. This will prevent concrete from cementing the screws in place and will make removal of the blades easier later on.

Warning: Do not lift the trowel overhead with a float pan attached, as the pan could fall off and strike personnel working in the vicinity.

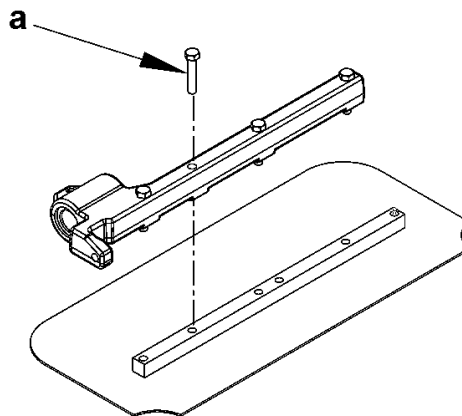

3.4 Before Starting

Before starting the machine, check the following items:

- All handles are free from grease, oil and dirt.
- All control levers are in the neutral position.
- All bolted joints are tightened.
- Oil level in gearbox
- Condition of Ring Guard
- Condition of trowel arms and blades

3.5 Handle Installation and Adjusting

- 3.5.1 Un-pack the handle assembly and the lower unit from the boxes. Check to make sure no damage was done during shipment.
- 3.5.2 Unfold the handle and secure it with nut (A).
- 3.5.3 All buttons on the handle display panel are in the off state.
- 3.5.4 Insert the control cable plug (B) into socket (C) to complete the installation..

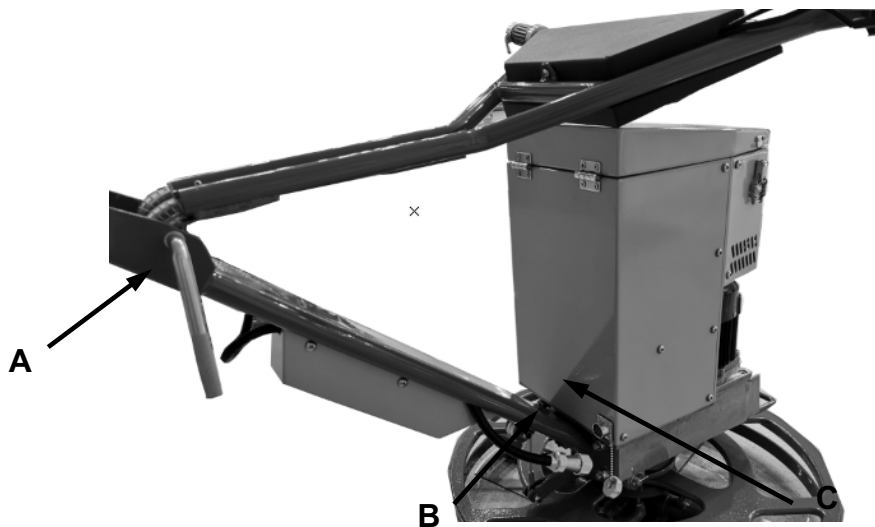

3.6 Safety Stop Switch

The switching mechanism of this switch should operate freely and should always be kept in this condition. With the switch in the OFF position, the motor should not start or run. The purpose of this switch is to stop the motor in a runaway situation, (i.e. the operator releasing the handle during operation).

3.7 To Start

- Make sure that the machine is equipped with the right blades.
1. Make sure that the main power is connected to the machine.
 2. Grip the handle and the Safety Stop Switch.
 3. Start the machine by pressing the key switch to "ON".
 4. Never let go of the handle during operation.

3.8 To Stop

Reduce RPM to "0" by moving the speed control. Release the safety stop switch. Turn the key switch to "OFF".

3.9 Speed Control

The motor speed can be set on Auto and Manual mode.

Speed Control on Auto: In Auto speed mode, adjust the motor speed suitable for real-time working conditions, clockwise to increase, counterclockwise to decrease MIN(0 min/n)~MAX(120 min/n).

Speed Control on Manual: In Manual speed mode, turn the handle for adjust speed.

3.10 Pitch Adjustment

To adjust blade pitch (angle) by fast pitch control. Pull the control knob all the way reverse (towards to the operator) to increases the pitch of the blades. Push the control knob all the way forward (away from the operator) to flattens or decreases the pitch of the blades.

3.11 Floating Operation

Attach float blades to the trowel arms, and when the concrete has set sufficiently to support the weight of the trowel, place the unit on the concrete. Start the unit and engage the blades as previously instructed. Using the tilt adjustment knob to adjust the blades to the float position-blades should be as flat to the concrete as possible with enough tension kept on the tilt adjustment cable to prevent the unit from dancing or chattering.

This operation will bring the water and fines to the surface, allowing for a smoother finish when finishing the concrete.

3.12 Finishing Operation

After floating, allow the concrete to set until it will support the weight of the trowel. Set the pitch to approximately 1/4" to 3/8" on the blades. If the blades start to dig into the concrete, decrease the amount of pitch.

4. Electrical Schematic

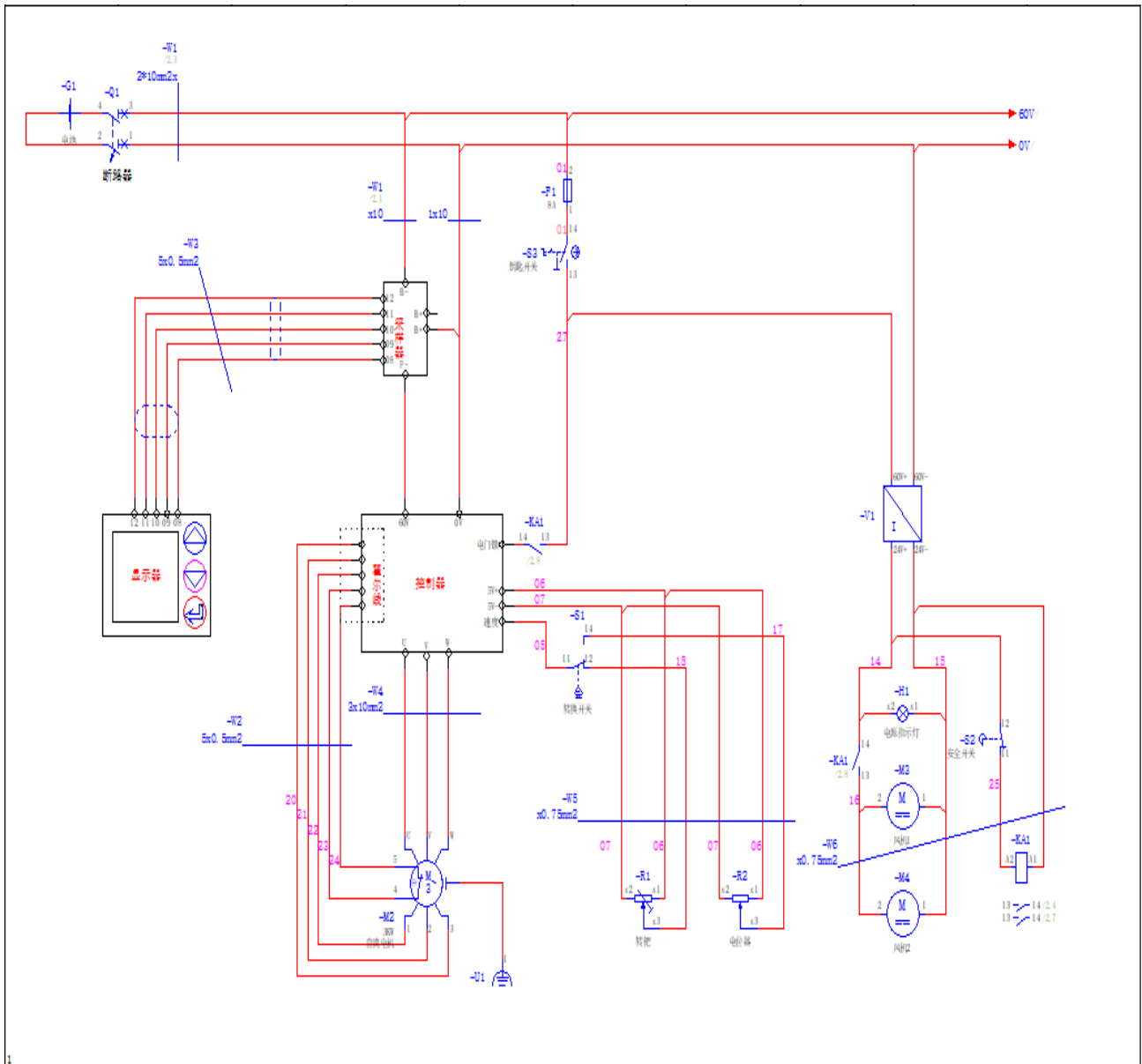

5 MAINTENANCE

5.1 Periodic Maintenance Schedule

The chart below lists basic trowel and motor maintenance.

	Daily	Every 20 hours	Every 50 hours	Every 100 hours	Every 200 hours	Every 300 hours
Check external hardware.	●					
Clean trowel after each use to remove concrete splatter.	●					
Grease blade arms		●				
Adjust blade speed						●
Replace oil in gearboxes.						●

5.2 Battery Maintenance

To retain the capacity of the batteries it is very important that the following handling instructions are observed.

After each use the batteries must always immediately be completely recharged.

This recharging is particularly necessary if the batteries will then be lying unused for around 3 weeks or longer.

Repeated storage without prior recharging will result in the batteries losing more and more charge power, with the charge power eventually dropping to 20-30% of the batteries original capacity.

5.3 Directions for Battery charger

- Connect the charger to the battery via the charging contact.
- Connect the mains cable to the wall socket.
- The red connection light comes on when charging commences.
- The green light comes on when the battery is ready for use.
- When the green and red lights are both on, the charger is continuing with adjustment/maintenance charging, and it should thus remain connected until the battery is used.
- Disconnect the mains cable from the wall socket.
- Disconnect the charger from the battery.

Caution: The battery emits explosive gases during charging, so avoid flames and sparks.

The charger must not be exposed to water.

The machine must not be connected to any power source while cleaning.

5.4 Lubrication

The long life and successful operation of any parts of machinery is dependent on frequent and thorough lubrication. Before using the machine, always check the oil and use proper oil with the correct type and grade as recommended.

NOTICE: DO NOT mix types of oil in gearbox and DO NOT overfill the oil. Damage to the machine may occur if oils are mixed or overfilled. See Technical Data for oil quantity and type.

5.5 Lifting Trowels

Use the lifting hook(a) when lifting machine. Make sure lifting device has enough capacity to hold machine (see identification plate on machine for weight).



5.6 Trouble Shooting

SYMPTOM	REMEDY
The machine won't start	<ul style="list-style-type: none"> ● Check whether the power switch is turned on. ● Check the control circuit fuse. ● Check if the transformer secondary coil has 24V output. ● Check the safety stop switch. ● Check the relay ● Check the speed control switch.
The power indicator does not light up.	<ul style="list-style-type: none"> ● Check the key switch. ● Check the control circuit fuse. ● Check if the transformer secondary coil has 24V output. ● Check indicator.
The fan does not work.	<ul style="list-style-type: none"> ● Check the control circuit fuse. ● Check if the transformer secondary coil has 24V output. ● Check the safety stop switch. ● Check the relay.

6. MACHINE ACCESSORIES

ITEM NO.	ACCESSORIES	MODEL	QTY
1	Allen wrench	1.2-10mm	1 SET
2	Double-ended wrench	8×10, 13×16, 17×19	1 SET
3	Adjustable wrench	200mm	1 PC
4	Phillips screwdriver	5×100	1 PC
5	Phillips screwdriver	#0×75	1 PC
6	Slotted screwdriver	3.2×75	1 PC
7	Fuse	5×20-6A	2 PCS

Bon[®]
Trusted since 1958

4430 Gibsonia Rd. • Gibsonia, PA 15044 • USA • www.bontool.com

IS17135 9/24